

CARRIER SYSTEMS 2013/2014



Atera

ATERA CARRIER SYSTEMS
STAND FOR
HIGHEST DEMANDS,
TECHNICAL INNOVATION,
AND FUNCTIONAL AESTHETICS.

WHETHER IT IS ABOUT
THE TRANSPORT
OF BICYCLES,
SKIS AND BOARDS,
CANOES AND SURFBOARDS,
ROOF BOXES, OR THE
ATERA WORK SERIES.

ATERA PRODUCTS ARE THE
OUTSTANDING RESULT
OF GERMAN DESIGN
AND ENGINEERING,
MANUFACTURED
IN LEUTKIRCH IM ALLGÄU.

ATERA – FOR A SAFE AND RELAXED JOURNEY FROM THE START.



Let's get ready to go! Atera is always coming along with you. Whatever the time of year, Atera always has the right carrier system for your destination. Atera roof boxes will make your summer holidays so much easier to organise, and your winter holiday fun also starts with an Atera roof box or ski carrier.

A great selection of bike carriers for tow bar mounting is waiting for bike enthusiasts, whether singles or families. We also have streamlined bike racks to carry the bikes on the roof.

The Atera Signo roof bars are the solid platform for anything you want to carry. In 2013 we are introducing a unique new roof bar range. The new Signo RT with Aero Profile and the Signo RT foot derives from the fusion of aesthetics and function. The reduced air drag and fuel consumption are impressive as well as the further developed stability and safety.

The systematic selection of high grade materials and the professional workmanship are decisive features for the quality and durability of our products. Shapely, anodised functional aluminium profiles and high-tech glass fibre-reinforced components give a unique look, high stability and a high level of safety reserves to each Atera product – even in exceptional situations.

Not without good reason have Atera carrier systems been test winners on several occasions in recent years; they are recommended by experts. The relentless pursuit of continuous improvement, the passion, determination and ambition to create the perfect transport solution, is our motivation.

What nobody can see, but what is also an important part of Atera carrier systems, is the full compliance with the strict standards of the automotive industry as well as international standards for security and environmental protection.

Atera's comprehensive automotive quality management system guarantees the constant process safety in production and long-lasting satisfaction with our carrier systems. Certificated quality, Made in Germany.

In spite of all these thoughts about technology and safety we do not lose sight of our basic goal: Your enjoyable leisure activities. The fun really starts when you load your gear – and this is what matters!

We wish you many pleasant journeys.
Yours faithfully Martin Baumeister

Atera GmbH · Im Herrach 1 · 88299 Leutkirch im Allgäu, Germany
info@atera.de · www.atera.de

Atera

THIS IS
WHAT
MATTERS.



Atera Basic

Basic racks Signo clamping roof bars / Signo fix point roof bars / Signo special roof bars /	6 - 7
Signo rail roof bars Roof Bars for roof rails The new Signo RT with aero bars	8 - 9

Atera Sport

Bicycle roof carrier Giro AF	10 - 11
Bicycle- / racing bike roof carrier Giro Speed / Giro front wheel holder	12 - 13
Bicycle rear carrier Linea for estates / station wagons, transporters and vans / extension kits	14 - 15
Bicycle rear carrier for tow bars Strada	16 - 21
Strada DL / Strada Sport M / Strada E-Bike M / extension kits	18 - 19
Strada Evo / Strada Vario / extension kits	20 - 21
Roof boxes Cargo, Certo, Certo Design, Formula / roof box lift	22 - 25
Ski- and snowboard carriers Nova	26 - 27
Water sport equipment carriers for boats / surfboards / kayaks	28 - 29

Atera Work

Carrier systems for heavy duty / high roof / raised roof / T4 / fix point / load basket	30 - 31
Accessories high angle bracket / angle bracket / lateral support bracket / cross connector / ladder holder / roller / universal gripper	

Atera Accessories

Lashing strap / tensioning ratchet / distance holder / lock sets	32 - 33
Signs of transport competence	35

The new Atera Strada Vario can be folded to the compact size of 63 x 39 cm and stowed in the boot in a matter of seconds.



ROOF RACKS

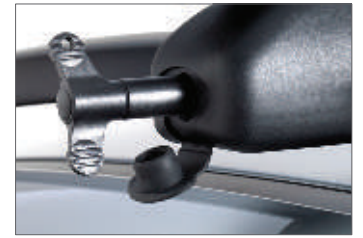

SIGNO

The perfect fit for each car

Signo stands for precision and stability and provides the solid platform for the Atera Sport carriers and the Atera Work programme. The swivelling support feet ensures the perfect horizontal alignment of the cross bars to each other – a special design achievement, which clearly shows that Atera sets a high value on optimal transport conditions and clean design.

The integral design of the Signo series is the ideal partner for any type of vehicle. The Signo range provides the perfect match for any vehicle whether rail, fix point, clamp mounting or even for extreme roof heights. Signo roof racks are preassembled and ready to fit – even technically inexperienced people are able to mount the carriers safely and precisely.

Key benefit

Due to the unique coded Atera key no additional tools are required to mount the system. At the same time - like any key system, the coded Atera keys have different codes, which protects the roof rack against theft.



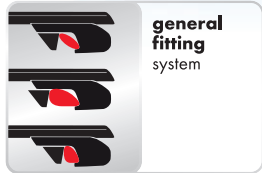

general fitting system

SIGNO RAIL RACK

For all vehicles with open roof rails. To find the matching roof rack, please check out our product finder on our web site www.Atera.de or our printed application list.

- Preassembled and ready to use out of the box
- Extreme low height
- Top only 50 mm above the rail
- Longer or shorter bars are available should you change to a wider or narrower vehicle
- Loading width from 110 to 150 cm
- Compatible to rail sizes from 15 to 55 mm
- Rubber padded clamping
- Mounting with Atera coded key
- Protected against theft by the coded Atera key
- For steel bars, 32 x 20 mm
- For aluminium bars 57 x 30 mm

SIGNO CLAMPING RACKS

For fixation in the door area. To find the matching roof rack, please check out our product finder on our web site www.Atera.de or our printed application list.

- Preassembled and ready to use out of the box
- Made-to-measure
- Loading width from 110 to 150 cm
- Car paint protecting, coated clamping plates
- Protected against theft by the coded Atera key
- For steel bars, 32 x 20 mm
- For aluminium bars 57 x 30 mm

SIGNO FIX POINT RACKS

For cars with pre-installed fixing points. To find the matching roof rack, please check out our product finder on our web site www.Atera.de or our printed application list.

- Preassembled and ready to use out of the box
- Made-to-measure
- Loading width from 110 to 150 cm
- Car paint protecting, coated clamping plates
- Protected against theft by special screws
- For steel bars, 32 x 20 mm
- For aluminium bars 57 x 30 mm

SIGNO SPECIAL RACKS

For cars with integrated roof rails. To find the matching roof rack, please check out our product finder on our web site www.Atera.de or our printed application list.

- Preassembled and ready to use out of the box
- Made-to-measure
- Loading width from 110 to 150 cm
- Car paint protecting, coated clamping plates
- Protected against theft by the coded Atera key
- For steel bars, 32 x 20 mm
- For aluminium bars 57 x 30 mm



RAIL RACKS

NEW
AVAILABLE
FROM
AUGUST 2013

SIGNO RT

Powerful. Quiet. Efficient.

The Signo RT – the superior masterpiece with Aero Profile and the Signo RT foot derives from the fusion of aesthetics and function.

The Aero Profile Atera sets a new benchmark. The reduced air drag and fuel consumption are impressive as well as the further developed stability and safety.

It fits to any open roof rail, whether high, wide, thick or thin – handy for all vehicle brands and models. Stylish, elegant and subtly integrating with contemporary vehicle designs, the Signo RT fits perfectly on the roof, straight out of the box. The Atera Signo RT is the solid platform for anything you want to carry.

German quality standard: Typical Atera.



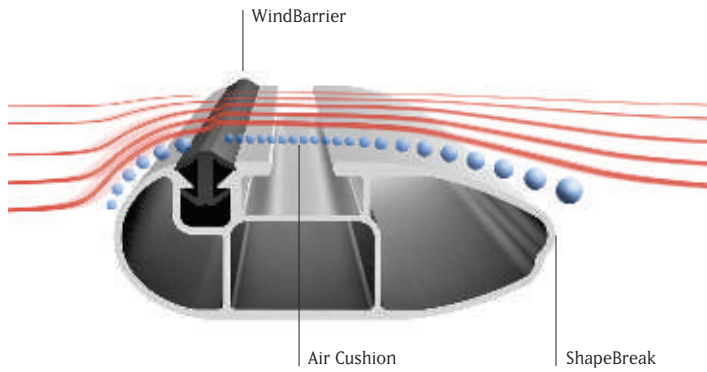

ATERA AERO PROFILE

An aerodynamic revolution – the Atera Aero Profile:

Instead of continuing the drop shape, Atera introduced at the trailing edge a special designed ShapeBreak, that controls the airflow in a favourable way. At the same time the ShapeBreak improves the stability of the cross bar and helps to keep its weight low.

The WindBarrier is a deflector for the airstream and is an important element, with its origin in aeronautics: The WindBarrier creates small swirls, forming an Air Cushion on the surface of the cross bar.

The ingenious purpose of the WindBarrier is the Air Cushion bridge for the airstream above the T-Slot that prevents the development of wind noise under all driving conditions. Even in unloaded condition it isn't necessary to cover the T-Slot.

ATERA SIGNO RT

The mounting to the roof rails is very simple: Just put the preassembled Signo RT on the roof rails. Adjust the width without tools by sliding the feet in the slot in the cross bar.

The fixation of the width and at the rail is done at the same time.

The perfect fastening torque is secured by the Atera torque hex wrench with T-handle.

The Aero Profile is compatible with all Atera accessories.

Signo RT roof bars

- Preassembled ready to use out of the box
- Perfect fit to many vehicles
- Atera torque hex wrench
- Payload 100 kg
- Cross bars: from 110 - 150 cm
- Theft protected by cylinder lock
- Clamping jaws with rubber
- For steel cross bars
- For Aero Profile



BICYCLE ROOF RACKS



GIRO AF

Focus on Know-How

With the Giro AF Atera proves how years of experience, combined with a profound knowledge about the latest technical processes and materials, was expertly transferred into the design process. The Giro AF, shapely and streamlined, looks good on the roof. The distinctive clamping system holds your precious and valuable bike securely. Suitable for wheels from 20 to 29 inches, with bulky MTB-tyres to thin racing bike tyres, and with strong or slim frames. Giro AF, the practitioner, awarded 2nd place in the ADAC test 2011 and Stiftung Warentest 6/2011.

Wheel Protection

"Competence in professional cycling". It's appropriate for Atera to advertise this headline. Other suppliers pay little attention to the protection of the goods being carried, but Atera particularly cares for this. The Atera wheel holders are deliberately formed like wheel-chocks in order to eliminate the enormous lateral, drag and shear loads. Thus the wheels are protected against any damage – a small detail with a big effect.

GIRO AF

ITEM. NO.: 082 220

Bicycle roof rack made of matt anodized aluminium with automatic holding function.

- preassembled
- no pre-adjustment required
- no tools required
- Easily changed from right hand to left hand mounting
- double anti theft protection
- thick rubber coating to protect the bike frame
- comfort clamping system
- The quick release ratchet accommodate all common wheel sizes
- 2,9 kg lightweight
- for steel cross bars 32 x 22 mm
- for all aluminium cross bars
- City Crash tested
- TÜV tested

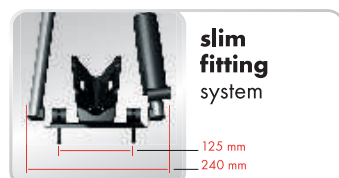
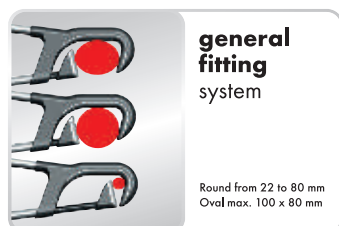

The Giro AF holds round frames from 22 to 80 mm and oval frames up to 100 x 80 mm. Holding function: After the bike comes to rest between the wheel holders, the bike leans against the open clamping head, holding itself in a vertical position before the clamp is shut.





RACING BIKE ROOF RACKS

GIRO SPEED



Pure Profession

The professional bicycle carrier with an impressive design for racing bikes or mountain bikes. With the Giro Speed everything is all about speed. Mounted within seconds, the fork fixing and the "Wheel Protection" wheel holder will put you in high-speed to the road.

Turn – push – ready!
The Giro Speed offers additional performance related features; important to professional bikers: lightweight and safety.



GIRO SPEED

ITEM No.: 082 221

Bicycle roof rack with fork fixation for racing and or mountain bikes also suitable for disk brakes.

- safe and quick fixation
- "Wheel Protection" wheel holder for the back
- anodized aluminium V-rail
- completely preassembled
- no pre-adjustment required
- no tools required
- anti theft protection
- for steel cross bars 32 x 22 mm
- for all aluminium cross bars
- City Crash and TÜV tested
- please consult the manufacturer before using with carbon forks
- not suitable for thru bold axles



wheel protection



city crash certified

GIRO FRONT WHEEL HOLDER

ITEM No.: 082 223

Accessory for the Giro Speed. Also suitable for bikes with disk brakes.

- theft retarding screws
- matt anodized aluminium
- completely preassembled
- for steel cross bars 32 x 22 mm
- for all aluminium cross bars
- not suitable for thru bold axles

BICYCLE REAR CARRIERS

LINEA

For a versatile range of vehicles

Linea is designed for vans, transporters, estates, ... vehicles with tailgates. Simple mounting without drilling.

The Linea sets consists of the carrier base and the vehicle specific mounting kit. The specific mounting kit ensures a perfect and simple fit.

At vehicle changes it is sufficient to replace the mounting kit, when the vehicle is within the same class. Linea can be extended with additional bike rails.

Linea shows bike transport competence in every detail. Wheel holders with "Wheel Protection". Lockable bike frame holders with rotating joints accommodate diameters from 30 to 80 mm. The frames and tubes are made of top quality anodized aluminium or stainless steel.





LINEA 2 FOR ESTATE / HATCH BACK

ITEM No.: 024 501

Carrier base made of anodized aluminium. Vehicle specific mounting kit required. To find the vehicle specific mounting kit, please check out our product finder on our web site www.Atera.de or our printed application list.

- width: 1,31 m
- completely preassembled
- supplied as standard with 2 bike rails
- two lockable distance holders
- wheel holder with quick fix
- coded key theft protection
- optional third bike rail

LINEA 2 VAN / TRANSPORTER

ITEM No.: 024 503

Carrier base made of anodized aluminium. Vehicle specific mounting kit required. To find the vehicle specific mounting kit, please check out our product finder on our web site www.Atera.de or our printed application list.

- width: 1,31 m
- completely preassembled
- supplied as standard with 2 bike rails
- two lockable distance holders
- wheel holder with quick fix
- coded key theft protection
- optional third bike rail

LINEA 3 VAN / TRANSPORTER

ITEM No.: 024 500

Carrier base made of stainless steel and anodized aluminium. Vehicle specific mounting kit required. Bike rails.

- width: 1,31 m
- completely preassembled
- supplied as standard with 3 bike rails
- three lockable distance holders
- wheel holder with quick fix
- coded key theft protection
- optional fourth bike rail

EXTENSION KIT FOR 3RD BIKE

ITEM No.: 024 550

Extension for Linea 024 501 / 024 503. Bike rail with lockable distance holder. Uses existing fixing points on the carrier base.

EXTENSION KIT FOR 4TH BIKE

ITEM No.: 024 551

Extension for Linea 024 500. Bike rail with lockable distance holder between the 3rd and 4th bike. Uses existing fixing points on the carrier base.



LINEA MOUNTING KITS

ITEM No.: 021 107 — 021 155

For all Linea carrier bases. The specific mounting kits ensure a perfect, simple fit.

- 2 supports with coated vehicle specific tail gate clamps
- anti-theft protection
- completely preassembled



LINEA ALL-IN-ONE SYSTEMS VOLKSWAGEN T4 AND T5,

Available with 2 or 3 bike rails. To find the vehicle specific system, please check out our product finder on our web site www.Atera.de or our printed application list.



The tailgate can be opened even when the carrier is loaded.

BICYCLE TOW BAR CARRIERS

STRADA

Strada bicycle carriers – the benchmark for weight and comfort.

Atera offers with the new Strada models a uniquely wide range of products with different price categories and features; all for mounting on the tow bar.





BICYCLE TOW BAR CARRIERS



STRADA



	STRADA DL 2	STRADA DL 3
Item number	022 600	022 601
Number of bikes	2	3
Number of e-bikes	-	-
Dimensions in mm (W x H x D)	1000 x 250 x 560	1000 x 250 x 720
Weight in kg	12,2 kg	14,4 kg
Maximum load in kg	47 kg	45 kg
Bike sizes	all	all
Frame diameters in mm	25 - 80	25 - 80
Tyre sizes	all	all
Bicycle theft protection	yes	yes
Carrier theft protection	yes	yes
Lighting system	integrated, with fender	integrated, with fender
Plug connection	13-pin	13-pin
Base frame material	steel / aluminium	steel / aluminium
Bike rail distance	180 mm	180 mm
Bike rail number / quality	2 / matt anodized aluminium	3 / matt anodized aluminium
Lockable distance holders	2	3
Type approval	EC Type Approval	EC Type Approval
Warranty	3 years	3 years

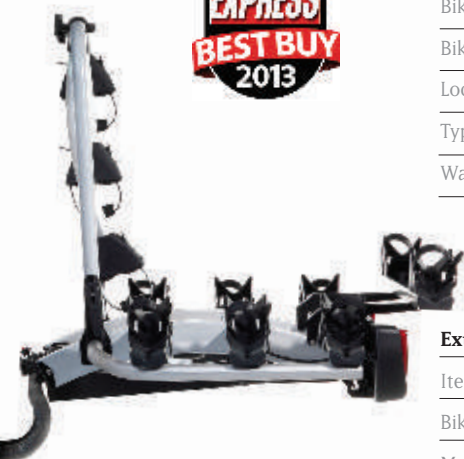

Extension Kits

	022 610	022 611
Item number	022 610	022 611
Bike rail / distance holder	1 / 1 long	1 / 1 bike to bike / + belt strap
Maximum total load in kg	45 kg	63 kg



All Atera tow bar carriers have the EC Type Approval. The permissible maximum mass on the tow bar has to be at least 50 kilos with two bicycle 60 kilos with three bicycle

Strada DL 2
Comfort carrier for two bicycles.
 Extendable to 3 bikes.
 Easy access to the boot thanks to the weight bearing roller system – comfortable and fast, whether loaded or unloaded.
 Even vertical tailgates can be easily opened with the Strada DL.
 An ultra light and extremely stable bicycle carrier.

Strada DL 3
Comfort carrier for three bicycles.
 Extendable to 4 bikes.
 Easy access to the boot thanks to the weight bearing roller system – comfortable and fast, whether loaded or unloaded. Even very big vertical tailgates of vans can be easily opened with the Strada DL 3.

AutoExpress Test Winner: Best Buy 2013
 Read more: www.autoexpress.co.uk

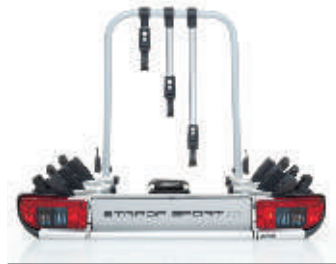
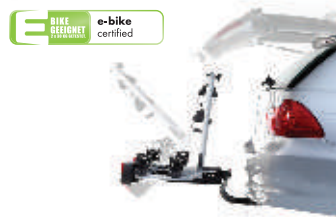

STRADA SPORT M 2

022 684

2
2
1000 x 200 x 590
13,5 kg
60 kg
all
25 - 80
all
yes
yes
integrated, with fender
13-pin
steel
180 mm
2 / matt anodized aluminium
2
EC Type Approval
3 years

STRADA SPORT M 3

022 685

3
2
1000 x 200 x 720
16,5 kg
60 kg
all
25 - 80
all
yes
yes
integrated, with fender
13-pin
steel
180 mm
3 / matt anodized aluminium
3
EC Type Approval
3 years

STRADA E-BIKE M

022 686

2
2
1000 x 200 x 590
14 kg
60 kg
all
25 - 80
all
yes
yes
integrated, with fender
13-pin
steel
230 mm
2 / matt anodized aluminium
2
EC Type Approval
3 years

Highly Developed Atera Standards:

You'll find Atera perfection in each Strada. The benchmark for professional bicycle transport.

- complete preassembled
- tilting / roll bearing mechanism with safety interlock
- self adjusting quick coupling
- incorrect mounting impossible
- Wheel Protection wheel holders
- padded distance holders
- quick release ratchet tensioners
- easy tyre positioning
- extension kits
- fits into the boot
- matt anodized aluminium
- theft protection for carrier
- theft protection for bikes
- EC Type Approval
- TÜV tested



022 610

1 / 1 long
68 kg



022 624

1 / 1 bike to bike
68 kg



022 624

1 / 1 long
68 kg



DRIVE-UP RAIL

ITEM No.: 022 635

Loading aid for all Strada DL, Strada Sport M and Strada E-Bike M carriers.

Strada Sport M 2

High-Performance carrier for 2 bicycles or 2 e-bikes.

Extendable to 3 bikes.

The tilting mechanism facilitates the fast access to the boot – whether loaded or unloaded. An ultra-light and stable bicycle carrier. Crash and double-lane change manoeuvre tested.

The optional drive-up rail enables the comfortable loading.

Test winner in the last major ADAC test 2011.

Strada Sport M 3

High-Performance carrier for 3 bicycles or 2 e-bikes.

Extendable to 4 bikes.

Features see Strada Sport M2

Strada E-Bike M

High-Performance carrier for 2 bicycles or 2 e-bikes.

Extendable to 3 bikes.

The distance between the bike rails is 230 mm, plenty of space for drive unit or battery.

Also the perfect choice for downhill bikes with wide suspension forks.

Features see Strada Sport M2

BICYCLE TOW BAR CARRIERS



STRADA

STRADA Evo 2

STRADA Evo 3

Item number	022 700	022 701
Number of bikes	2	3
Number of e-bikes	2	2
Dimensions in mm (W x H x D)	1080 x 330 x 590	1080 x 280 x 735
Weight in kg	16,3 kg	19,8 kg
Maximum load in kg	60 kg	66 kg
Bike sizes	all	all
Frame diameters in mm	25 - 80	25 - 80
Tyre sizes	16 - 29 inch	16 - 29 inch
Bicycle theft protection	yes	yes
Carrier theft protection	yes	yes
Lighting system	integrated	integrated
Plug connection	13-pin	13-pin
Base frame material	Steel / Aluminium	Steel / Aluminium
Bike rail distance	190 mm	190 mm
Bike rail number / quality	2 / matt anodized aluminium	3 / matt anodized aluminium
Lockable distance holders	3	3
Type approval	EC Type Approval	EC Type Approval
Warranty	3 years	3 years



Extension Kits

Item number	022 710	022 711
Bike rail / distance holder	1 / 1 long	1 / 1 bike to bike
Maximum total load in kg	60 kg	66 kg



All Atera tow bar carriers have the EC Type Approval. The permissible maximum mass on the tow bar has to be at least 50 kilos with two bicycle 60 kilos with three bicycle

Strada Evo 2

Innovative design carrier for 2 bicycles or 2 e-bikes.

Extendable to 3 bikes. Rear lights with modern clear-glass look – distinctive and extensive for better illumination and visibility for increased safety. High-grade aluminium distance holder frame equipped with detachable, lockable distance holders, which can be positioned freely. The roll bearing pullout is the new reverence concerning comfort and handling and impresses with its smooth operation especially when loaded.

Strada Evo 3

Innovative design carrier for 3 bicycles or 2 e-bikes.

Extendable to 4 bikes. Even very big vertical tailgates of vans can be easily opened with the Strada Evo 3.

Additional features see Strada Evo 2.

aktiv
Radfahren
05/2013
Testsieger

bike 06/12
TEST FAHRRADTRÄGER URTEIL: SEHR GUT
Atera Strada Sport M2

05/2012
Trekkingbike
sehr gut

Auto Bild
GUT
2012

TOUR
TEST-SIEGER
ATERA
STRADA SPORT M2
Heft 6/2012
Radträger



STRADA VARIO 2

STRADA VARIO 3

022 750

022 751

2

3

2

2

1140 x 750 x 640 / 635 x 420 x 670

1140 x 730 x 740 / 635 x 470 x 740

16,4 kg

19,9 kg

60 kg

66 kg

all

all

25 - 80

25 - 80

18 - 29 inch

18 - 29 inch

yes

yes

yes

yes

integrated

integrated

13-pin

13-pin

Steel / Aluminium

Steel / Aluminium

190 mm

190 mm

2 / matt anodized aluminium

3 / matt anodized aluminium

2

3

EC Type Approval

EC Type Approval

3 years

3 years



Strada Vario 2

The foldable masterpiece for 2 bicycles or 2 e-bikes.

Stunning look: The highlight for your safety are the distinctive clear-glass look rear lights. Extensive designed underrun protection with dual function: Safety and continuation of the dynamic line of the vehicle. Mounted on the car or stowed back again in the boot in a matter of seconds. High-grade aluminium distance holder frame equipped with detachable, lockable distance holders which can be positioned freely. The roll bearing pullout is the new reverence concerning comfort and handling and impresses with its smooth operation especially when loaded.

Strada Vario 3

The foldable masterpiece for 3 bicycles or 2 e-bikes.



CARRYING BAG FOR VARIO 2
ITEM No.: 022 760

Black tear resistant polyester fabric with two short carrying handles & zip.

CARRYING BAG FOR VARIO 3
ITEM No.: 022 761

Wheel Protection

"Competence in professional cycling". It's appropriate for Atera to advertise this headline.

Atera particularly cares for the protection of the goods being carried.

The Atera wheel holders are deliberately formed like wheel-checks in order to eliminate the enormous lateral, drag and shear loads. Thus the wheels are protected against any damage – a small detail with a big effect.

Frame Protection

Also the protection of the bike frame is an important matter for Atera.

Dents and scratches are often the result of non-professional fixing solutions and / or the use of cheap, hard materials, which are not appropriate to absorb high forces.

Atera is doing more to protect valuable bikes: The lockable Strada distance holders can be swivelled and turned in each direction. For the theft protection the ratchet straps are enforced with a steel core while the bike frame itself is held soft and secure by soft rubber cushions.

Even the ratchet system itself is equipped with an overload protection: The desired tension is reached by using the ratchet – when the tension exceeds the desired level, the ratchet band automatically jumps to the next tooth. The optimal tension remains and is secured when the ratchet lever is locked. Consequently it is impossible to crush the bike frame.



wheel protection



pump fix system



folding concept

IN PREPARATION

DRIVE-UP RAIL, ITEM No.: 022 741

Loading aid for all Strada Evo and Strada Vario.

ROOF BOXES



CARGO, CERTO, FORMULA

Traveling in top form.

Expand your transport capacity with attractive Atera roof boxes.

Enjoy the added value during the transport of all your items you don't want to miss –comfortable, dry and protected against theft.

All roof boxes are compatible to steel and aluminium cross bars.

Atera roof boxes are TÜV-approved, city crash certified and come with a warranty of 5 years.

Dual-Side Opening

Mount them on the left of the roof, in the middle, or on the right.

Atera roof boxes offer all-round comfort due to the dual side opening*.

*Except Cargo 810 and Certo 410





Lowered Base

The lowered base not only provides additional space, but also the visual integration to the car and the drag coefficient show the value of Atera Certo roof boxes.

Stainless Steel Diffusor

More than an eye-catcher: The diffusor makes the aerodynamics of the Atera Formula series almost perfect.

Dynamic Opening

Innovative, safe and comfortable. The knee lever mechanism supports the opening and closing of the box.

Quick-Fix

Quick and tool-free mounting with the patented fitting systems. Compatible with steel and aluminium cross bars

Easy-Fit:

1. Put the box on the roof
2. Adjust to the distance of the cross bars
3. Insert bracket from below and close EASY-FIT fastener- a half turn is sufficient.

Master-Fit:

1. Put the box on the roof
2. Adjust to the distance of the cross bars
3. Turn the MASTER-FIT and press the red cap – secured!

Premium-Fit:

1. Put the box on the roof
2. Adjust to the distance of the cross bars
3. Turn Premium-Fit to the noticeable clicking



ROOF BOXES

The Atera Cargo entry-level models are functional & practical. Atera Cargo boxes are available in two sizes and offer all you need for a relaxed journey.

- Highest safety.
- Easy mounting due to the Easy-Fit System.
- Knee lever mechanism that supports the opening and closing.
- Integrated steel rail for safe fixation.
- Impact resistant ABS / ASA material.
- Lowered base for outstanding aerodynamics.
- Lowered distance to the roof to reduce wind noise.
- Lockable.
- Low weight.
- 5 years warranty.

The Atera Certo quality. Due to the patented Master-Fit the mounting of the box is child's play. Four Sizes – the perfect box for every purpose.

- Reduced warming due to the silver-coloured lid.
- Highest safety.
- Master-Fit
- Knee lever mechanism that supports the opening and closing.
- Integrated steel rail for safe fixation.
- Impact resistant ABS / ASA material.
- Lowered base for outstanding aerodynamics.
- Lowered distance to the roof to reduce wind noise.
- Central locking system.
- Low weight.
- 5 years warranty.



ATERA CARGO

ATERA CERTO



Model	ATERA CARGO 810	ATERA CARGO 830	ATERA CARGO 831	ATERA CERTO 410	ATERA CERTO 420	ATERA CERTO 460	ATERA CERTO 560
Item number	082270	082271	082272	082260	082261	082262	082263
Colour	Anthracite	Anthracite	Silver Grey	Silver Metallic	Silver Metallic	Silver Metallic	Silver Metallic
Material	ABS / ASA	ABS / ASA	ABS / ASA	ABS / ASA	ABS / ASA	ABS / ASA	ABS / ASA
Outer Dimensions L/W/H	142/82/42	178/78/42	178/78/42	149/98/42	178/78/42	192/82/42	216/91/44
Volume (Litre)	330	410	410	400	400	440	550
Empty weight (kg)	12	14	14	14,5	14,5	17,5	20,5
Maximum Load (kg)	75	75	75	75	75	75	75
Mounting	Easy-Fit	Easy-Fit	Easy-Fit	Master-Fit	Master-Fit	Master-Fit	Master-Fit
Opening	rear	on both sides	on both sides	right side	on both sides	on both sides	on both sides
Locking System	1 Lock	Central locking system	Central locking system	Central locking system	Central locking system	Central locking system	Central locking system
Warranty	5 Years	5 Years	5 Years	5 Years	5 Years	5 Years	5 Years
Reinforced bottom with metal rail	yes	yes	yes	yes	yes	yes	yes
Look	grained surface	grained surface	grained surface	grained silver surface	grained silver surface	grained silver surface	grained silver surface
Comfort fitting set for T-Slot mounting (optional)	Item No. 082193	Item No. 082193	Item No. 082193	Item No. 082266	Item No. 082266	Item No. 082266	Item No. 082266

Features (all): Cargo lashing straps, lashing lugs, dynamic opening system, central locking, quick fix system to roof bars

The exclusive Atera Certo Design roof boxes. For a dazzling appearance – with glossy surface. Optimised aerodynamics combined with excellent loading capacity. The dual side opening lid guarantees the highest loading comfort. Additional features:

- Brilliant glossy surface.
- High quality ABS / PMMA material with highest UV-Resistance.
- Highest safety.
- Knee lever mechanism that supports the opening and closing.
- Integrated steel rail for safe fixation.
- Outstanding mounting comfort with Master-Fit system.
- Lowered base for outstanding aerodynamics.
- Dual side opening.
- Central locking system.
- Low weight.
- 5 years warranty.

Atera Formula, the highest level in roof box aesthetics.

The silver carbon surface shows from afar the bright characteristics of these high-end series. The streamlined shape guarantees a perfect aerodynamic and low noise emission. The diffusor ensures that the aerodynamics of the Atera Formula series is almost perfect. More than an eye-catcher:

- Unique glossy surface with silver carbon look
- High quality ABS / PMMA material with highest UV-Resistance.
- Knee lever mechanism that supports the opening and closing.
- Integrated steel rail for safe fixation.
- Excellent mounting comfort due to the Premium-Fit system with torque control.
- Lowered base for outstanding aerodynamics.
- Dual side opening.
- Central locking system.
- Low weight.
- 5 years warranty.

ATERA CERTO DESIGN

ATERA FORMULA



ATERA CERTO 480	ATERA CERTO 480 W	ATERA CERTO 580	ATERA FORMULA 980	ATERA FORMULA 990
082264	082267	082265	082280	082281
Brilliant Black	Brilliant White	Brilliant Black	Silver Carbon	Silver Carbon
ABS / PMMA	ABS / PMMA	ABS / PMMA	ABS / PMMA	ABS / PMMA
192/82/42	192/82/42	216/91/44	191/80/37	215/88/37
440	440	550	380	460
17,5	17,5	20,5	19	23,5
75	75	75	75	75
Master-Fit	Master-Fit	Master-Fit	Premium-Fit	Premium-Fit
on both sides	on both sides	on both sides	on both sides	on both sides
Central locking system	Central locking system	Central locking system	Central locking system	Central locking system
5 Years	5 Years	5 Years	5 Years	5 Years
yes	yes	yes	yes	yes
glossy black metallic effect	glossy pure white	glossy black metallic effect	Glossy carbon look with stainless steel diffusor	Glossy carbon look with stainless steel diffusor
Item No. 082266	Item No. 082266	Item No. 082266	Item No. 082266	Item No. 082266



COMFORT FITTING

Optional.
For easy mounting in the T-Slot of aluminium cross bars. Theft-proof.

ROOF BOX LIFT

ITEM No.: 082 195
Ideal for the storage of the roof box, e.g. in a garage. Simple mounting.

SKI-/+ SNOWBOARD- CARRIERS

NOVA



In January 2012 the Auto Express rated the Atera Nova Ski Carrier as Best Buy: „Best buy: There’s a quality feel to these Atera carriers – the only ones on test to offer height adjustment for both square and aero bars. They’re easy to put together, with bolts securing the neat twist-and-grip clamps. Everything you need is in the box, including a T-handle hex wrench. Loading skis is simple, too, thanks to the big release button, sprung arm and snap-shut lock...”

Read more: www.autoexpress.co.uk





At the highest level.

Clear lines with the highest levels of user-friendliness, form and durability. For winter sports enthusiasts the Nova is a design classic that will prove itself again and again.

With its straightforward handling – even with thick gloves – the winter fun starts while loading. Simply Atera.

NOVA 4

ITEM No.: 082 724
Carrier for
1 Snowboard und 1 pair of skis
Or for up to 4 pair of skis

- **Width outside:** 570 mm
- **Loading width:** 400 mm
- for all roof racks
- complete preassembled
- height adapter for extreme high ski-bindings included
- elastic rubber, even at cold temperatures
- big push button
- snap-lock theft protection
- for steel cross bars 32 x 22 mm
- for all aluminium cross bars

NOVA 6

ITEM No.: 082 726
Carrier for
2 Snowboard und 1 pair of skis
Or for up to 6 pair of skis

- **Width outside:** 780 mm
- **Loading width:** 610 mm
- for all roof racks
- complete preassembled
- height adapter for extreme high ski-bindings included
- elastic rubber, even at cold temperatures
- big push button
- snap-lock theft protection
- for steel cross bars 32 x 22 mm
- for all aluminium cross bars



WATER SPORT CARRIERS

BOOT / SURF / KAJAK

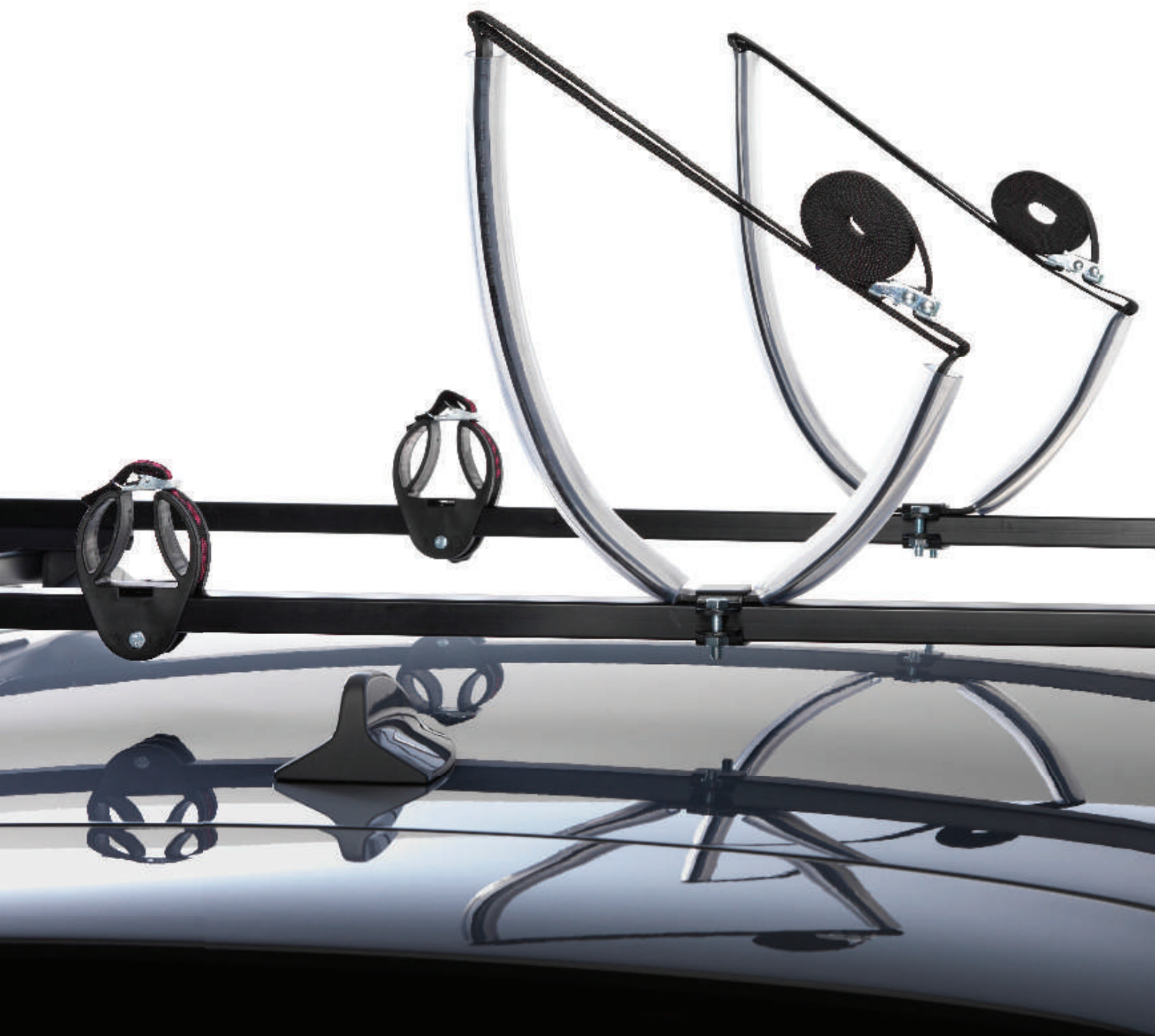

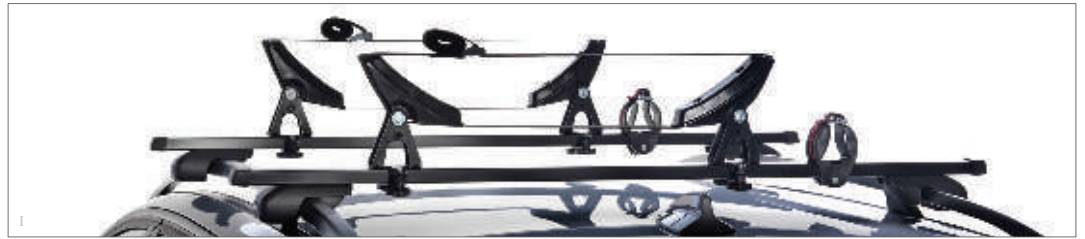

All on board.

The Atera water sport carriers have been developed in team work with surfers and canoeists to fulfil their demands on the transport, mounting and loading comfort.

The result is high functional carriers, which cope with the high weight and wind pressures.

Using the water sport carriers is child's play and as intuitive as possible due to their clear design. Simply Atera!

BOAT CARRIER

ITEM No.: 089 033

For the transport of small boats and canoes on the roof. Universal adjustable hard rubber rests. Maximum load 100kg.

The complete set contains:

- 4 adjustable hard rubber rests
- 2 belt straps
- 2 paddle holders

Only for steel cross bars 32 x 22 mm

SURFBOARD CARRIER

ITEM No.: 089 048

For the transport of surfboards on the roof. Sheathed, special shaped carrier for the perfect lateral support.

The complete set contains:

- 4 coated metal holders
- 2 belt straps
- 2 paddle holders

Only for steel cross bars 32 x 22 mm

KAYAK CARRIER

ITEM No.: 089 048

For the transport of kayaks on the roof. Sheathed, special shaped carrier for the perfect lateral support.

The complete set contains:

- 2 coated metal holders
- 2 belt straps
- 2 paddle holders

Only for steel cross bars 32 x 22 mm



LOAD CARRIERS



WORK

ATERA WORK LOAD BASKETS

For Transporters.
Plug-in and screw system.
To find the matching roof rack, please check out our product finder on our web site www.Atera.de or our printed application list.

- width: 1,25 / 1,40 / 1,65 m
- minimum basket length 1,60 m
- tube diameter 20,5
- zinc coated
- flat packed / compact shipping size
- perfect for long vehicles

FITTING KIT

ITEM No.: 089 025
For fixation of the load baskets to steel cross bars
1 Set = 4 pieces
Only for steel cross bars 32 x 22 mm
1 Set for two cross bars

ATERA WORK SL

For cars with rain gutter and high roof.
To find the matching roof rack, please check out our product finder on our web site www.Atera.de or our printed application list.

ITEM No.: 081 978

Height: 250 mm

ITEM No.: 081 979

Height: 300-350 mm

ITEM No.: 081 980

Height: 400-500 mm

- supports supplied in pairs
- cross bars must be ordered separately
- zinc coating
- with black plastic coating
- load capacity: max. 100 kg
- rubber coated clamping
- TÜV tested





ATERA WORK TWENTY

ITEM No.: 081 802

For vehicles with rain gutter and raised roof. To find the matching cross bars, please check out our product finder on our web site www.Atera.de or our printed application list.

- supports supplied in pairs
- cross bars must be ordered separately
- for steel cross bars 32 x 22 mm
- zinc coating
- with black plastic coating
- load capacity pair of supports: max. 100 kg
- TÜV tested



RAIN GUTTER SUBSTITUTE

ITEM No.: 089 328

Stable side mount for Atera rain gutter roof racks
1 Set = 4 pieces

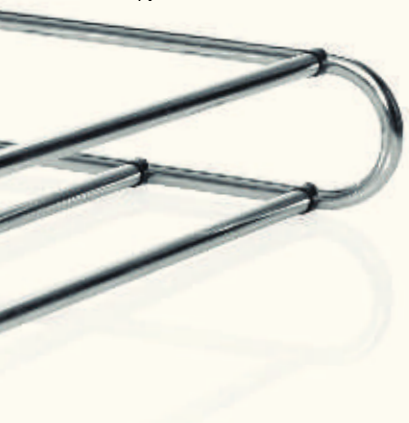

ATERA WORK HD

System for vehicles with rain gutter and high roof. To find the matching roof rack, please check out our product finder on our web site www.Atera.de or our printed application list.

- supports supplied in pairs
- cross bars must be ordered separately
- extendable height from 190 to 830 mm
- zinc coating
- for steel cross bars 32 x 22 mm

Attention: The higher the bracket, the lower the loading capacity of the support brackets:

Height	190 - 350 mm:	100 kg
Height	350 - 500 mm:	75 kg



HD ROOF SUPPORT

ITEM No.: 089 098

For high profile racks above 500 mm height an additional support is required.

- continuously adjustable foot
- zinc coated
- 1 Set = 2 pieces

ATERA WORK T4

ITEM No.: 081 293 / 081 294

Patented carrier especially designed for the VW T4.
Minimum 2, maximum 4 cross bars.

- supports supplied in pairs
- cross bars must be ordered separately
- for steel cross bars 32 x 22 mm
- zinc coating
- with black plastic coating
- load capacity pair of supports: max. 100 kg
- TÜV tested

Work T4 installation scheme with item number for pair for supports:

081 293 081 293 081 293 081 294

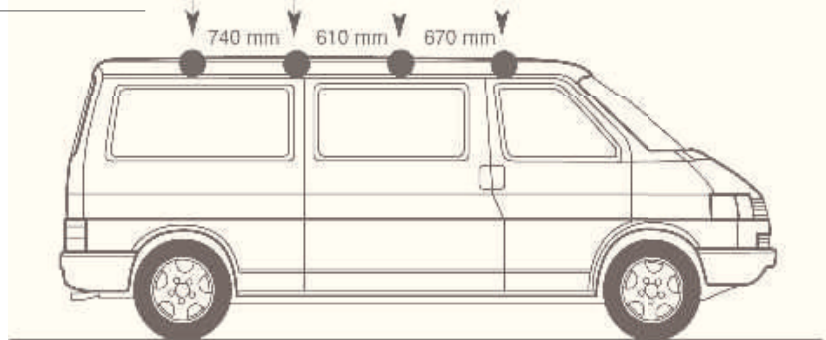
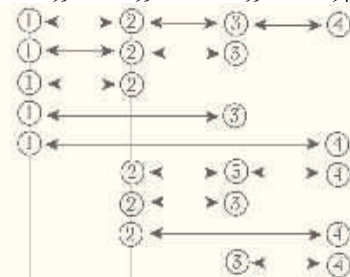

ATERA WORK FIX RACKS

These racks are screwed directly onto the pre-installed fixing points. To find the matching roof rack, please check out our product finder on our web site www.Atera.de or our printed application list.

- preassembled and ready to use out of the box
- made-to-measure
- loading width up to 150 cm
- protected against theft by special screws
- car paint protecting, coated clamping plates
- for steel bars, 32 x 20 mm
- for aluminium bars 57 x 30 mm
- TÜV tested

LOAD CARRIER ACCESSORY

WORK

LADDER HOLDER pic. 1

ITEM No.: 089 107

- for steel cross bars 32 x 22 mm
- formed flat steel
- zinc coated
- height: 180 mm
- easy mounting with knurled screw
- for two stepladders or one combination ladder
- 1 Set = 4 support angles
1 upper stop bar and 2 tensioners

LARGE SUPPORT BRACKET pic. 2

ITEM No.: 089 071

- for steel cross bars 32 x 22 mm
- double tubular steel bracket
- zinc coated
- 2 mm sheathing
- height: 200 mm,
- 1 Set = 4 Brackets

SMALL SUPPORT BRACKET pic. 3

ITEM No.: 089 070

- for steel cross bars 32 x 22 mm
- double tubular steel bracket
- zinc coated
- 2 mm sheathing
- height: 130 mm,
- 1 Set = 4 Brackets



ACCESSORIES

UNIVERSAL GRIPPER

Gripper with textile strap for skis, paddles, surf masts, ...
With knurled screw

ITEM No.: 089500: 8 pieces

ITEM No.: 089501: 2 pieces

RATCHET STRAP TENSIONER

ITEM No.: 089 006

- strap length 4000 mm
- strap width 25 mm
- zinc coated ratchet

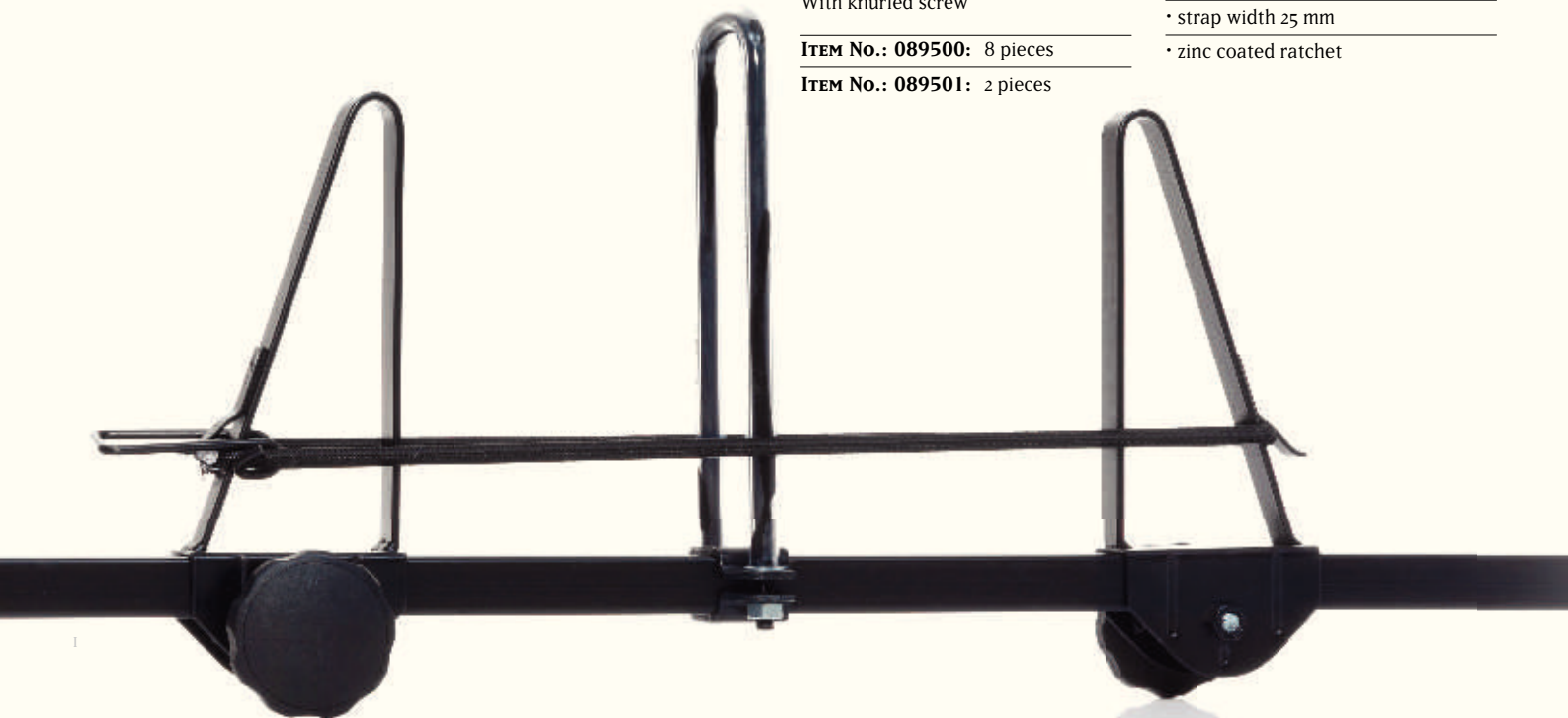



HIGH ANGLE BRACKET pic. 4

ITEM No.: 089 029

- for steel cross bars 32 x 22 mm
- formed flat steel
- zinc coated
- height: 180 mm
- easy mounting with knurled screw
- 1 Set = 4 pieces

ANGLE BRACKET pic. 5

ITEM No.: 089 024

- for steel cross bars 32 x 22 mm
- formed flat steel
- zinc coated
- height: 90 mm
- easy mounting with knurled screw
- 1 Set = 4 pieces



CROSS CONNECTOR pic. 6

ITEM No.: 089 510

- zinc coated
- to connect two steel cross bars 32 x 22 mm

ROLLER FOR STEEL CROSS BARS pic. 7

ITEM No. 082 309

- facilitates the loading of long goods
- synthetic roller
- easy mounting with knurled screw
- width 600 mm
- diameter 50 mm



LASHING STRAPS

ITEM No.: 089 901 pic. 8

- length: 300 mm / Width: 17 mm
- stainless safety latch
- 4 Pieces

ITEM No.: 089 902 pic. 8

- length: 400 mm / Width: 17 mm
- stainless safety latch
- 4 Pieces

ITEM No.: 089 907 pic. 9

- length: 2500 mm / Width: 25 mm
- stainless safety latch
- 2 Pieces

ITEM No.: 089 908 pic. 9

- length: 4000 mm / Width: 25 mm
- stainless safety latch
- 2 Pieces.



DISTANCE HOLDERS STRADA

The Strada distance holders can be swivelled and turned in any direction. The bicycle frame is tightened perfectly to the distance holder by a padded and steel reinforced ratchet strap. The lock mounting is prepared. (The lock must be ordered separately)

ITEM No.: 022 630

- (Strada 1st holder) only DL Sport M, E-Bike
- length Alu-Tube: 30 mm

ITEM No.: 022 631

- (Strada 2nd holder) only DL and Sport M
- length Alu-Tube: 200 mm

ITEM No.: 022 632

- (Strada 3rd holder) only DL and Sport M
- length Alu-Tube: 400 mm

ITEM No.: 022 634

- (Strada 2nd holder) only E-Bike M
- length Alu-Tube: 250 mm

ITEM No.: 022 633 pic. 10

- bike to bike connection

DISTANCE HOLDERS LINEA

The Linea distance holders can be swivelled and turned in any direction. The bicycle frame is tightened perfectly to the distance holder by a padded and steel reinforced ratchet strap. The lock mounting is prepared. (The lock must be ordered separately)

ITEM No.: 099 518

- (Linea 1st holder)
- length Alu-Tube 140 mm

ITEM No.: 099 519

- (Linea 2nd holder)
- length Alu-Tube 320 mm

ITEM No.: 099 520

- (Linea 3rd holder)
- length Alu-Tube 490 mm

LOCK SETS

For distance holders and the Giro, Nova, Strada and Linea product series. One set comes always common locking.

ITEM No.: 083 008

- 1 lock + 2 keys

ITEM No.: 083 013

- 2 locks + 2 keys

ITEM No.: 083 010

- 4 locks + 2 keys

ITEM No.: 083 011

- 6 locks + 2 keys

ITEM No.: 083 012

- 8 locks + 2 keys



WITH ALL ATERA
PRODUCT DEVELOPMENTS
OUR FOCUS IS CONSTANT,
FROM THE FIRST DESIGN SKETCH.
WE AIM TO ACHIEVE
PERFECTION IN DESIGN,
DURABILITY, USER COMFORT
AND FUNCTIONALITY.



SIGNS OF TRANSPORT COMPETENCE.

The straightforward product range with hands-on products to test brings Atera customers faster to the most appropriate transport solutions.

Therefore the best start to a journey is always with your Atera dealer; they know exactly what matters.

The perfect fitting carrier systems for your vehicle, service, fast deliveries, safety issues, ... whatever you've got on your mind – don't hesitate to call us:

Service hotline:
+49 75 61- 98 344 1324

Those who follow the media will repeatedly come across positive reviews and recommendations for Atera products.

It might not say Atera, but many car manufacturers' own-brand equipment comes from Atera. Great functionality, continuous development and the respected production is highly appreciated by many of the leading vehicle manufacturers.

Atera products are designed and made in Germany. Manufactured in accordance to DIN ISO 75302, TÜV tested.

Atera products come with three years warranty on material and function. Five years on roof boxes.

According to the EU regulation DIN EN ISO 1135 all synthetic parts are completely recyclable. Our production meets the requirements of the German environment protection rules and is constantly monitored in order to ensure the compliance.

A comprehensive quality management system guarantees not only top quality products, but also ideal conditions for deliveries and trade.



Environmental Management in accordance to System IAF. ISO 14001:2004 in development, manufacturing & sales.



Bike carrier recommendation for the transport of heavy e-bikes.



Professional design department based in Leutkirch im Allgäu, Southern Germany.



All Atera Certo Design roof boxes come with a five years warranty



Designed in Leutkirch im Allgäu – innovative, functional and award winning.



Carrier and load are secured during frontal crash at 30 km/h and remain on the vehicle.



Atera products come with a three years warranty on material and function.



Atera wheel holders are formed like wheel-chocks and secure a firm hold – even during exceptional driving manoeuvres.



Atera products are designed and manufactured in accordance to DIN ISO 75302 – TÜV tested.



Wheel holders and distance holders are equipped with quick release ratchets – these ensure additional tensioning force.

ADAC AND STIFTUNG WARENTEST TEST WINNER*



* Best tow bar carrier
for E-Bikes.